



Sykes-Pickavant®

Workshop Solutions

SPECIAL OFFERS & NEW PRODUCTS

APRIL - JUNE 2012

HEAVY DUTY COIL SPRING COMPRESSOR

08390000

- Features double-ended hex drive for ease of use
- Heat treated, self lubricating operating screw
- Supplied with two sets of jaws

NEW



ALSO AVAILABLE:

Spacer Block - For use with asymmetric / tapered springs



08390600

EXCLUSIVE
SP Design

SEE PAGE 12 FOR FURTHER DETAILS



EPB SERVICE & RESET TOOL
PAGE 2



VAG FUEL PUMP PRESSURE TESTER
PAGE 4



GEN2 BEARING REMOVAL KIT - 78mm
PAGE 10



BALL JOINT SUPER SET
PAGE 20



www.sykes-pickavant.com



ELECTRONIC SERVICE

Tyre Pressure Monitoring – Sensor Testing and Activation Tool

SP 30661000

TPMS TOOL - All-Makes Service Tool

TPMS Features:

- Test feature allows for checking operation of sensors and sensor batteries
- Selects model specific sensors only
- Includes sensor specific technical data
- Built-in sensor checking – no exciter tool required
- Check sensors individually, or full car
- Print and save test reports for your customers
- Investigate and troubleshoot sensor malfunctions
 - E.G. High / Low pressure readings, internal air temperature, damaged sensors etc
- Sensor replacement procedures for specific applications
 - Includes torque value for fitting new sensor
 - Includes OEM sensor part number for reference
 - Includes OEM valve component references
 - Includes sensor replacement & tyre rotation procedures
- Annual Update available for new models (€165.00)

€649.95

- Sensor Activation
- Sensor Checking
- Sensor Replacement
- All in one single tool!



Additional Features:

- Print test results / file test results (via PC)
- Update the software / applications (via PC)
- Displays procedures for new sensors to be synchronised with ECU (pairing)
- Software upgrade available for full ECU re-programming



Code Sensor Reading

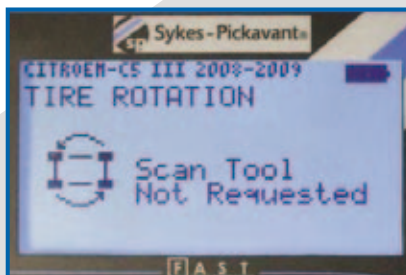

Tyre Rotation / Set-Up

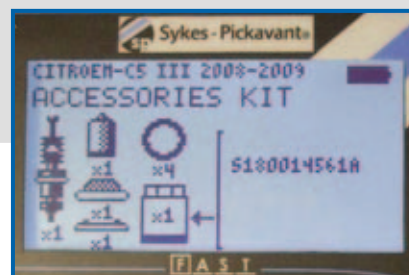

Accessories Kit

SP 30661500

TPMS PLUS - All-Makes Service Tool

All the features of the standard TPMS Tool (above), PLUS the following additional features:

1. Sensor re-programming via the EOBD socket
2. Sensor fault code reading / deletion
3. System enabling / disabling
4. Pressure / Battery condition / Temperature readings
5. Summer / Winter tyre set up
6. Sensor and ECU testing and pairing procedures

€1295.00



ELECTRONIC SERVICE

All-Makes Service Tool for electronically controlled Brake Service functions

NEW

SP 30662000

EPB Service & Reset Tool

An All-Makes Service Tool for electronically controlled Brake Service functions

- Functions included:
 - EPB – brake pad replacement
 - CAL – brake pad calibration
 - Reset – brake service reset
 - Fluid Purge – ECU controlled brake fluid change
- Make & Model search facility
- Read & Clear Error Codes (EPB / ABS / ESP)
- Graphic Screen images
- Annual Update available for new models (€165.00)
- Range coverage includes:
 - 24 vehicle manufacturers and over 120 individual models

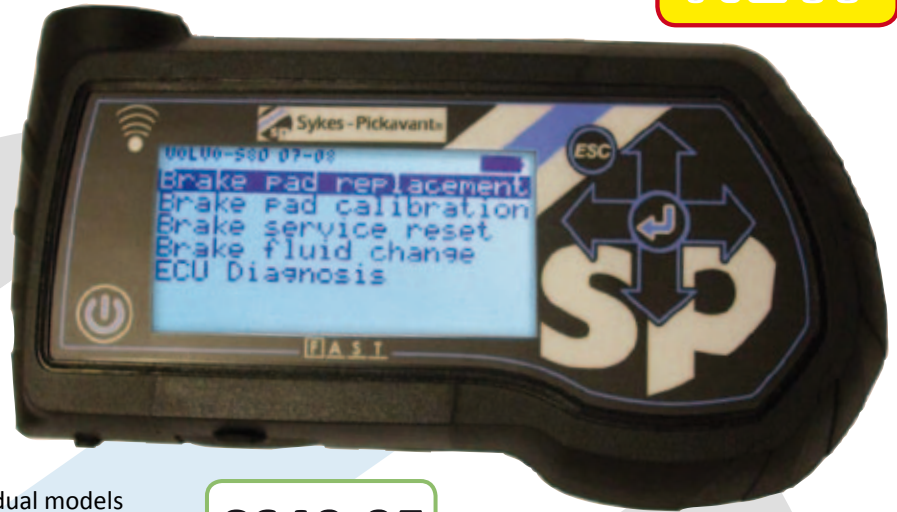

€649.95

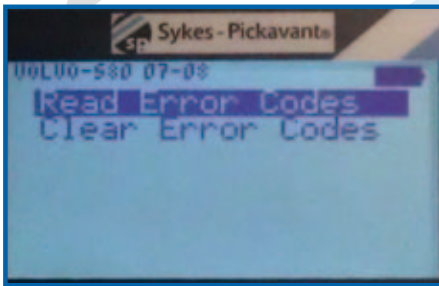

Read & Clear Codes

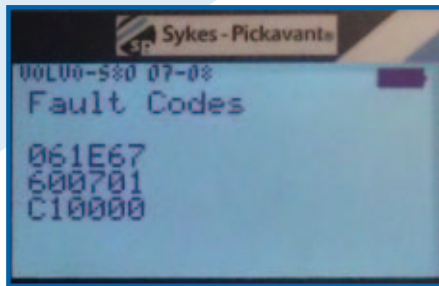

Brake System Fault Codes

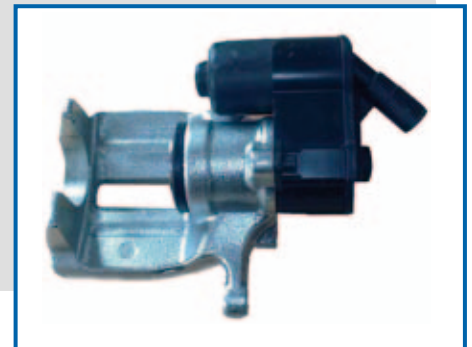

VW EPB Caliper

EPB caliper controlled via the ECU - electronic rewind is necessary for changing the brake pads

EPB Tool – Applications Range

Make	Function(s)
Audi	EPB/CAL
BMW	Reset
Chrysler	Fluid Purge
Citroen	EPB/CAL/Fluid Purge
Chevrolet	EPB
Dodge	Fluid Purge
Fiat	Fluid Purge
Ford	EPB/CAL/Fluid Purge
GM	EPB/CAL/Fluid Purge
Hyundai	Fluid Purge
Iveco	Fluid Purge
Jeep	Fluid Purge
Kia	Fluid Purge
Lancia	EPB

Make	Function(s)
Land Rover	EPB
Mercedes	EPB/Fluid Purge
MG	Fluid Purge
Nissan	Fluid Purge
Opel	EPB/CAL/Fluid Purge
Peugeot	EPB/CAL/Fluid Purge
Renault	EPB/Fluid Purge
Rover	Fluid Purge
SMART	Fluid Purge
Ssangyong	Fluid Purge
Toyota	Fluid Purge
Vauxhall	EPB/CAL/Fluid Purge
VW	EPB/CAL
Volvo	EPB



Renault EPB Controller & Motor
EPB controller with integral ECU for operating electronically controlled Hand (park) Brake

Full application details by model, available at: www.sykes-pickavant.com



PRESSURE TESTING

SP 31405000

Petrol Compression Test Set

- Enables easy access to deep seated plug ports
- Positive lock chuck ensures adaptors cannot be left in spark plug port
- Specially designed self-centering adaptors ensure minimal risk of cross threading

• Contents:

- 10mm / 12mm / 14mm Universal Adaptors
- 14mm Ford Duratec Adaptor
- 20 bar Pressure Gauge Assembly with 500mm braided high pressure hose

OFFER €195.95
SAVE €29.50
LIST PRICE €225.45

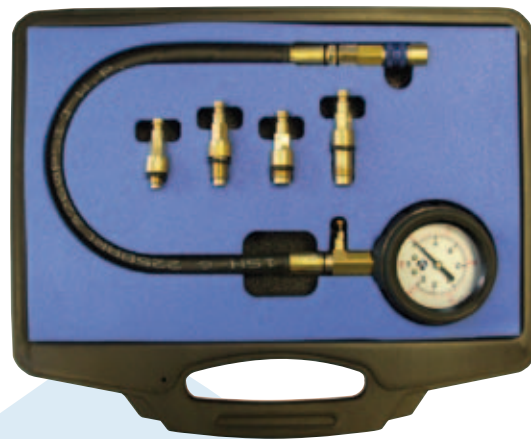

SP 31402000

Petrol Engine Compression Tester - Extra Long Hose

- Similar to 31400000 (below) but has an extra long flexible rubber hose for easy access to restricted plug ports
- 460mm flexible rubber hose

OFFER €64.95
SAVE €5.93
LIST PRICE €70.88

SP 31400900

Extra Long Flexible Adaptor Ford Zetec / Duratec

OFFER €39.95
SAVE €3.93
LIST PRICE €43.88



SP 31401100

Extra Long Flexible Adaptor Renault M12

OFFER €42.95
SAVE €5.99
LIST PRICE €48.94



SP 31400000

Petrol Engine Compression Tester

- Checks cylinder compression to assist in the diagnosis of faulty valves, piston rings, cylinder heads and gaskets
- 300mm flexible rubber hose
- M14 / M18 dual thread coupling
- 20bar Pressure Gauge

OFFER €59.95
SAVE €8.23
LIST PRICE €68.18

SP 31428500

Diesel Compression Test Kit Land Rover - Specialist Kit

- Checks engine compression under cranking conditions
- Enables cylinder access through glow plug adaptors
- Built-in pressure relief valve enables repeat tests without dismantling
- Kit contains 0 - 60 bar pressure gauge and 4 x Glow Plug adaptors
- **Applications include:**
Defender MK3, Discovery 3 & 4, Range Rover Sport & Range Rover 3, Freelander 1 & 2, Evoque
- Other adaptors for older Land Rovers are also available on request

OFFER €129.95
SAVE €25.30
LIST PRICE €155.25



SP 314200V2

Diesel Engine Compression Testing - Standard Car Kit

- Comprehensive test kit for both direct and indirect diesel injected engines
- Checks engine compression under cranking conditions
- Enables cylinder access through dummy injector and glow plug adaptors
- Built-in pressure relief valve enables repeat tests without dismantling
- **Contents:**

- 560mm Rubber Hose
- Gauge Scale: 0 - 60bar, 0 - 860psi
- Gauge Diameter: 83mm
- Gauge to DIN16005, DIN16063, BS1780 standards

OFFER €279.95
SAVE €44.05
LIST PRICE €324.00

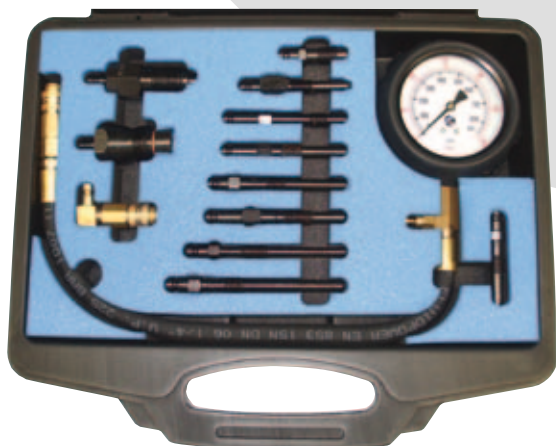

PRESSURE TESTING

Sykes-Pickavant offer a range of Fuel System Pressure Test Kits, covering both Petrol & Diesel applications, created from standard components using a 'mix & match' approach, allowing the user to select the most appropriate kit for their needs.

Features Include:

- Shock protected, fuel resistant dual scale gauge to 10bar / 145psi
- Relief valve for safe de-pressurisation
- Universal Applications

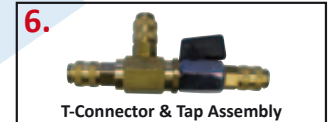
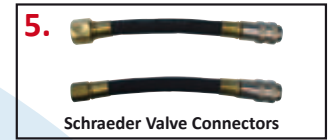
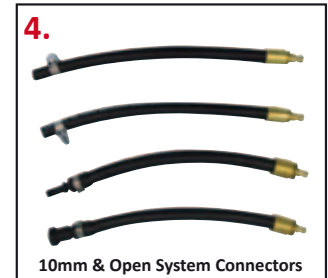
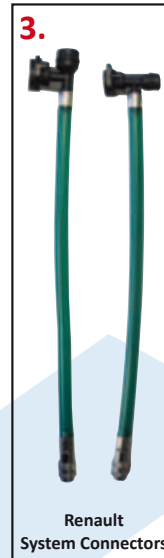
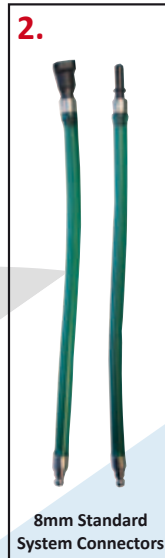

NEW **EXCLUSIVE**
SP Design

20bar Pressure Gauge

SP 31461000

Common Rail Diesel (CRD) Low Pressure Test Gauge Kit

- Measures Low Pressure feed from the fuel pump in the fuel tank to the High Pressure pump
- Brass Fittings & Heavy Duty high pressure hose for longer life
- Also measures fuel return pressure where necessary

OFFER €299.95
SAVE €51.05
LIST PRICE €351.00

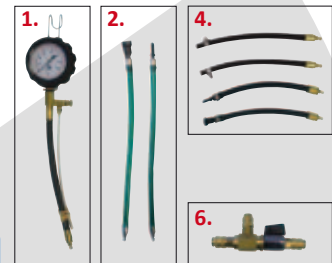

SP 31492000

VAG Fuel Pump Pressure Test Set (PD)

- A specially designed Fuel Pressure Tester for the PD range of engines as used by VAG
- 20bar Pressure Gauge – as PD fuel pumps operate at higher pressures than normal fuel pumps
- Extra long hose assembly for ease of access
- Special PD fuel pump quick connector



OFFER €119.95
SAVE €13.70
LIST PRICE €133.65

SP 31487500

Fuel Injection Pressure Test Kit For Petrol Engine vehicles

- A Universal kit for modern Electronic, Multi-point injection systems

OFFER €329.95
SAVE €54.80
LIST PRICE €384.75



SP 31468000

Fuel Injection Pressure Testing Combined Petrol & Diesel Kit

- A Universal Fuel Injection Pressure Test Kit for modern Electronic Multi-Point injection systems – both Petrol & Diesel in one kit

OFFER €399.95
SAVE €79.30
LIST PRICE €479.25



SP 31465000

Common Rail Diesel (CRD) High Pressure Test Kit

- Measures delivery pressure output from the CRD High Pressure pump (max 1700 bar) under engine cranking conditions
- Measures common rail pressure via the vehicles electronic pressure sensor with engine running
- M12 x 1.5 / M14 x 1.5 connections
- **Contents:**
 - High Pressure Gauge & Manifold block
 - Selection of High Pressure pipes
 - 2 x Adaptors
 - High Pressure Sensor Tester

OFFER €599.95
SAVE €102.05
LIST PRICE €702.00



PRESSURE TESTING

sp 31462000

Common Rail Diesel (CRD) Injector Fuel Return Flow Kit

- Designed for use on the injector return side of a CRD system
- Return flow / injector leak-back tester for up to six cylinders
- Injector adaptor sets for: Bosch / Delphi / Denso / Siemens
- Set of reduction pipes for small diameter flow back ports
- Under bonnet hanging hook

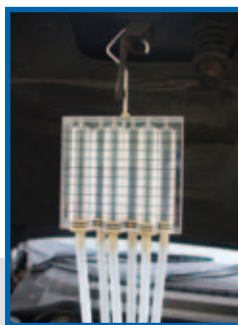

OFFER €259.95
SAVE €37.05
LIST PRICE €297.00



sp 31463000

Diesel Fuel System Bleeding Kit

- For priming / bleeding of diesel fuel filters, pumps and systems (Low Pressure side)
 - Prime fuel pumps
 - Test fuel feed system integrity using both Pressure and Vacuum
 - Search for air & fuel leaks

Contents

- Vacuum / Pressure pump with gauge
- Bleed bottle & accessories
- Universal diesel fuel system connection hoses
- Specialist connectors for Ford, PSA, Mercedes

OFFER €219.95
SAVE €29.80
LIST PRICE €249.75

sp 31440000

Catalyst Back Pressure / Vacuum Tester

- Measures the back pressure (or vacuum) via the Lambda Sensor socket, to indicate blocked or damaged catalytic converters
- Calibrated gauge scale indicates progressive pass / fail for tests at idle speed and for tests under load - coloured indication
- Suitable for M12 x 1.25 and M18 x 1.5 Lambda (Oxygen) Sensor sockets



OFFER €214.95
SAVE €21.30
LIST PRICE €236.25

sp 01391000

Vacuum & Pressure Pump Kit

- A complete test kit for a variety of automotive Vacuum and Pressure related tasks
- Hand Pump generates Vacuum or Pressure
- Supplied with accessories for:
 - Vacuum & Pressure system testing
 - Brake Bleeding
 - Fluid Siphoning



OFFER €89.95
SAVE €36.28
LIST PRICE €126.23

sp 31470000

Oil Pressure Test Set

- Helps to diagnose worn oil pumps & engines, faulty oil pressure switches and pressure warning indicators
- Shock protected dual scale gauge, for quick and accurate oil pressure checks
- Permanently oil primed, long flexible hose, enables access to difficult to reach oil switch ports
- Small profile, quick coupling adaptors with built-in shut-off valve for fast secure connection



OFFER €199.95
SAVE €32.25
LIST PRICE €232.20

PP319FTC

Power Probe 3 Probe – Connect – Detect!

- Connect to a vehicle battery and you have a multitude of testers at your fingertips!
- Power-up components
- Continuity tester
- Voltmeter
- Positive / Negative indicator
- Bad ground indicator
- Measures from 0 – 70 DC volts – in 1/10v increments

Kit Contents:

- Power Probe 3
- Cigarette Lighter adaptor
- Battery clips with heavy duty 4mm connectors
- 20' extension lead
- Instruction manual



€174.95



PPKIT03

Power Probe Master Combo Kit

- Master Kit includes a complete PPLS01 Lead Set, PPECT2000 Short & Open Circuit Detector, and a complete PP319FTC Power Probe3 Kit

NEW



€444.95

PPLS01

Power Probe Lead Set

- Extend the reach of your Power Probe or Multimeter with superior multi-strand leads for improved connectivity

Kit Contents:

- Two self-centering piercing probes
- 4mm banana jacks and adaptors – Gold Plated connections
- 1' – 3' – 6' long leads
- Male / Female convertors
- Probe Tip



€74.95

PPMT

Power Probe Micro Torch

- Small in Size – Big on Features – Easy to use
- Use for: Soldering, Brazing, Release Fasteners, Forming Plastics, Cutting
- Butane powered – 2 hours between refills
- 120 Watts, 580 BTU heat
- Max temp: 2500°F (as a torch) - 950°F (for soldering)



€67.95

PPSK

Power Probe Soldering Kit

- Portable Butane Gas Soldering Kit
- Electronic Ignition – Adjustable Flame Control
- Kit supplied with multiple tips for various applications and tube of solder
- 120Watts, 500 BTU heat



€74.95

PPECT2000

Power Probe Short & Open Circuit Detector

- 'SMART' Transmitter & Receiver
- Selection of probes, clips and adaptors
- Instruction CD

Features:

- Indicates direction to short
- Audible alert
- Isolate a circuit signal
- Detects through carpets and panels

€239.95



PPCT

Power Probe Scream'n Continuity Tester

- Self powered / portable continuity tester
- Adjustable, dual tone volume level
- Detects voltage
- Built-in Flashlight
- Ideal for Relay Testing, Circuit Testing, Harness Testing etc



€74.95

BRAKING

'270' Series Brake Pipe Flaring Tools - Speed - Accuracy & Reliability

- Vice mounted flaring tool
- Metric & imperial pipe sizes
- From 3/16" to 1/2"
- From 4.75mm to 12mm
- Produces both Convex and Double Lap flares to SAE and DIN standards
- Unique 'Dial-a-Size' Turret design

- Lever cam operation for quick flaring
- Automatic punch extraction from flare
- Screw clamp for accurate die alignment
- Variety of kits available to suit requirements
- All components available individually

SP 02700100

Brake Pipe Flaring Kit - 270 Series

- Suitable for brake pipe sizes:-
SAE Single & Double Lap flares - 3/16" & 4.75mm

OFFER €179.95
SAVE €63.05
LIST PRICE €243.00

SP 02700200

Brake Pipe Flaring Kit - 270 Series

- Suitable for brake pipe sizes:-
SAE Single and Double flares - 3/16", 4.75, 6, 8, 10mm
DIN Single flares - 4.75mm

OFFER €229.95
SAVE €91.35
LIST PRICE €321.30

SP 02700900

Brake Pipe Flaring Kit - 270 Series

- Suitable for brake pipe sizes:-
SAE Single and Double flares - 3/16, 1/4", 4.75, 6mm
DIN Single flares - 4.75mm

OFFER €199.95
SAVE €83.55
LIST PRICE €283.50



'272' Series Brake Pipe Flaring Tools - Flaremaster2®

The ever popular Flaremaster - with the ability to flare 4.75mm & 6mm Brake Pipes

- Hand-held flaring tool for on-the-vehicle pipe flaring

SP 02725600

Flaremaster2 for 4.75 & 6mm Brake Pipes

Includes: 02725000 - Flaremaster2



OFFER €179.95
SAVE €63.05
LIST PRICE €243.00

SP 02729600

Flaremaster2 Kit for 4.75 & 6mm Brake Pipes

Includes:

- 02725000 - Flaremaster2
- 02160000 - Pipe Aid Pliers
- 02210000 - Pipe Cutter
- 02730000 - Pipe Deburring Tool



OFFER €229.95
SAVE €67.05
LIST PRICE €297.00

SP 02726600

Flaremaster2 6mm Upgrade Kit

- Adds 6mm flaring capability to existing Flaremasters & Flaremaster kits

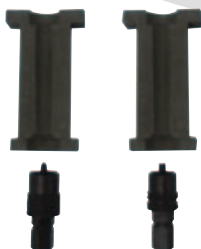

OFFER €39.95
SAVE €12.03
LIST PRICE €51.98

SP 02727500

Flaremaster2 Stainless Steel Pipe Upgrade Kit

- High Power Flaremaster Hydraulic Ram for pipe flaring on stainless steel brake pipes



OFFER €59.95
SAVE €14.30
LIST PRICE €74.25

BRAKING

SP 034800SP

€169.95

STAR BUY!

Vacuum Brake Bleeder c/w FREE Auto Filler (03481100)

A stand-alone brake bleeder that uses vacuum to "suck" fluid out of both brake nipples and reservoir

- Uses standard work shop compressed air supply to generate vacuum (70 – 170 psi)

Includes FREE Brake Fluid Auto Filler

- A stand-alone brake fluid container for automatic filling of brake fluid reservoirs
- Air tight brass tap ensures fluid stays "fresh" for next time



FREE!
WORTH €56.00

SP 03619200

Brake Caliper Piston Windback Master Kit

- A new and recently updated kit of Piston Windback adaptors
- Contents:
 - RH & LH Windback tools with hex drive
 - Reaction Plate
 - x12 popular application adaptors
- Applications list included

OFFER €269.95
SAVE €60.80
LIST PRICE €330.75



NEW



SP 036198SP

Air Assisted Caliper Piston Windback Tool c/w FREE Adaptors

- Air operated ram applies pressure to the caliper piston while the handle is rotated by hand

- Reversible – works on both RH and LH apps
- Supplied with 3 adaptors which cover a wide range of popular vehicles (applications list included)

OFFER €64.95
SAVE €19.43
LIST PRICE €84.38



Brake Caliper Cleaning File

Scraping file for removal of course residue on brake calipers. Special scraping surface saves time and is more effective than standard files because the coarse tooth design will not clog.

SP 03620100

Caliper Cleaning File

- Universal model for most vehicles

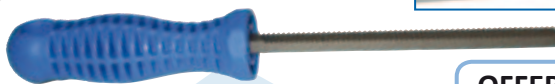

OFFER €29.95
SAVE €9.88
LIST PRICE €39.83

SP 03620200

Caliper Cleaning File

- Special extra slim model for Japanese vehicles



OFFER €34.95
SAVE €11.63
LIST PRICE €46.58

SP 03625000

4 in 1 Brake Pad Spreader

- One tool for both fixed and floating calipers
 - Fixed calipers – twin & quad piston
 - Floating calipers – single & twin piston
- Easy LH and RH use due to 180° swivel plate design
- Generates over 1600 ft.lbs of force to retract even the toughest caliper pistons



OFFER €139.95
SAVE €48.38
LIST PRICE €188.33

SP 03621000

Brake Caliper Piston Spreader (For single / twin piston calipers)

- Brake piston spreader for retracting the piston when fitting new brake pads
- Helps to prevent damage to pistons
- Suitable for a wide range of ATE, Delco, Bendix and Girling calipers
- Can be used with a T-bar, 1/2" D ratchet or spanner

OFFER €27.95
SAVE €2.43
LIST PRICE €30.38

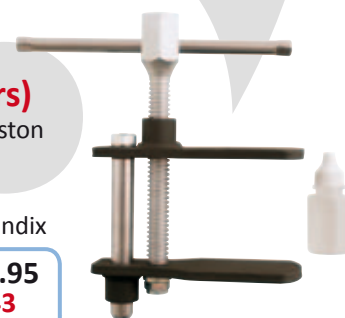

SP 03622000

Brake Caliper Piston Spreader (For quad piston calipers)

- Designed for quad pistons as fitted to BMW, Mercedes-Benz and others
- Maximum working range 88mm
- Suitable for use on twin / quad opposed pistons



OFFER €69.95
SAVE €14.43
LIST PRICE €84.38

SUSPENSION

SP 08780000

Universal Press & Pull Sleeve Set

Universal tool set for extracting and drawing in bushes, bearings, seals etc.

- Standard universal applications – Car – LCV – HGV



OFFER €599.95
SAVE €135.80
LIST PRICE €735.75

- Contains 20 x Press Sleeves
- Inside diameter range: 34 – 72mm
- Outside diameter range: 44 – 82mm
- 4 x step plates
- 4 x pulling spindles with thrust bearings
- Set 08780000 can be used on its own or with either the 18700000 Universal Press Frame or the 18780200 Universal C Clamp
- Can also be used in conjunction with model specific press piece sets or the standard workshop press

SP 18700000

Universal Press Frame

Universal tool for the dismantling & installation of suspension parts on the vehicle

- Suitable for Ball Joints, Suspension Bushes and other suspension components
- Powered by the SP1500 Series Hydraulic Ram
- Open frame design allows for parts to be pressed through the base



OFFER €249.95
SAVE €67.30
LIST PRICE €317.25

SP 08680000

Concentric Speedy Steering Rack Wrench

- For removal and installation of steering rack knuckles
- Suitable for knuckles with diameters 35mm to 45mm
- Works on all steering racks with track rods up to 30mm diameter
- Self locking rollers adjust automatically to the required knuckle diameter, to provide safe and secure grip
- Manufactured to OEM specifications, as required by Mercedes, PSA, Renault, Toyota, VAG etc
- Engineered to transmit forces through the centre line of the knuckle, for maximum performance and safety
- **High Quality grade steels:-**
 - Forged steel body
 - Heat treated steel rollers
 - Steel tube with 30mm diameter hex
- Serviceable – roller cage is replaceable should the rollers become worn or damaged



OFFER €129.95
SAVE €38.80
LIST PRICE €168.75

SP 18780200

Universal C Clamp

- Complementary tool for use with individual press piece sets
- Designed to allow greater access in restricted areas
- Special 'trapezoidal' threaded screw, allows for the application of greater force, and can be used with Impact Air Wrenches, as well as standard ratchets / wrenches etc



OFFER €469.95
SAVE €113.25
LIST PRICE €583.20

SP 08485000

Hub Clamp Spreader Tool

- Spreads the steering knuckle to enable removal and fitting of shock absorbers, without risk of damage to the knuckle
- Adjustable for use with knuckles which have either a centralised, or non - centralised slot
- Suitable for use on **both single and twin** knuckles
- **Single knuckles** as found on a wide range of vehicles
- **Twin knuckles** as found on modern VAG vehicles

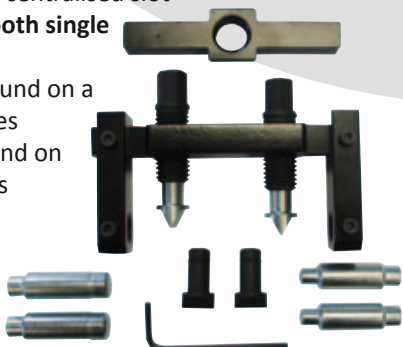

OFFER €64.95
SAVE €34.28
LIST PRICE €99.23

SP 08085000

Suspension Wear Indicator

- An innovative tool for detecting suspension and axle joint wear
- For detecting faults in:
 - Wheel bearings
 - Suspension joints and suspension struts
 - Stabilizers, bushes and ball-joints
 - Steering gear and links
- The tool creates a rocking motion in any direction (forward angle, side angle etc) in order to detect movement in steering and suspension components

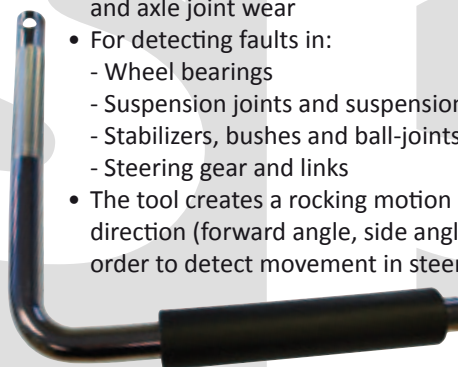

OFFER €59.95
SAVE €34.48
LIST PRICE €94.43

SP 08090000

CV Joint Puller

- For the removal of CV Joints on front wheel drive cars
- Avoids the need to remove the entire front axle
- No need to use a hammer – reduces risk of damage to the drive axle



OFFER €74.95
SAVE €22.93
LIST PRICE €97.88

BEARING REMOVAL

NEW

- The GEN 2 type of wheel bearing is predominantly fitted to models from Ford, Mazda, VAG and Volvo
- Includes a variety of different diameter tool kits covering a range of sizes to suit the different GEN2 bearings used by vehicle manufacturers
- Designed to distribute pressing force evenly through the outer bearing race
- Design allows for the suspension leg to remain in-situ on the vehicle when fitting new bearings

sp 08125500

GEN2 Bearing Removal Tool Kit - 72mm

- Applications:
Audi A1, Audi A2, Seat Cordoba, Ibiza, Skoda Fabia, Roomster, VW Polo (Front), VW Fox with PAS (Front)

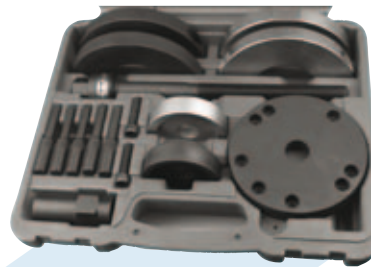

€319.95

sp 08123500

GEN2 Bearing Removal Tool Kit - 62mm

- Applications:
Audi A2, VW Lupo (Front)

€319.95



sp 08124500

GEN2 Bearing Removal Tool Kit - 66mm

- Applications:
Skoda Fabia, VW Fox (Front), Polo



€319.95

sp 08126500

GEN2 Bearing Removal Tool Kit - 78mm

- Applications:
Ford Focus II, C-Max, Mazda 3, Volvo C30, C70, S40 V50 (Front)

€349.95



sp 08127500

GEN2 Bearing Removal Tool Kit - 85mm

- Applications:
VW Multivan, Touareg, Transporter (Front / Rear)



€399.95

APPLICATION UPGRADE KITS ARE AVAILABLE ON THE 62mm, 66mm and 72mm SIZES ONLY
Each Upgrade Kit includes 2 x Back Plates and 2 x Adaptors

sp 08123000

GEN2 Bearing Removal Tool Kit - 62mm UPGRADE KIT

€219.95

sp 08124000

GEN2 Bearing Removal Tool Kit - 66mm UPGRADE KIT

€219.95

sp 08125000

GEN2 Bearing Removal Tool Kit - 72mm UPGRADE KIT

€219.95



SUSPENSION

sp 38480000

Pneumatic Coil Spring Compressor Workstation

Universal piece of equipment for assembling and disassembling struts and coil springs

- Suitable for cars, 4WD's and light commercials that use McPherson strut type suspension systems

ALS – Auto Levelling System

- Auto levelling upper arms simplify working on conical and misaligned springs

Brackets System

- Front and side spring clamps designed for fast changeover using unique Brackets System
- Aluminium Cylinder
- Can be used on extra-long shock absorbers (e.g. commercials) due to the long (330mm) stroke of the cylinder
- Manufactured from light alloy and resin to eliminate risk of corrosion and internal parts failure

Safety Guard

- Fitted Safety Guard for operator safety
- Also allows strut to be safely left in-situ if the equipment is disconnected from the air supply

Specifications

- Dimensions: 1400 x 520 x 300mm
- Working pressure: 10 bar (150 psi)
- Compression force: 1226 kg
- Cylinder stroke: 330mm
- CE approved

Contents

- Pneumatic Coil Spring Compressor Workstation
- Bracket A: 78 – 130mm
- Bracket B: 125 – 205mm
- Strut Vice
- Safety Guard

€1295.00



sp 38580000

Pneumatic Coil Spring Compressor Workstation – Extra Heavy Duty Model

- Specification as per model 38480000 (shown above) but fitted with Extra Heavy Duty Pneumatic Cylinder Compression force (at 10 bar) = 2452 kg
- Ideal for Extra Heavy Duty applications i.e. SUV's, 4WD's etc where full spring compression is required

New Features for 2012 model:

- Double-depth front plate for use on extra-long strut assemblies
- Safety locking valves system – locks safety cage and prevents usage with cage open

€1995.00



sp 38680000

Mechanical Coil Spring Compressor Workstation

- Simplified version of Workstation, but with Heavy Duty Mechanical Components instead of Pneumatics
- Ideal for mobile use, or where air supply is not practical
- Dimensions as per standard model
- Compression force: 1600kg
- Compression length: 330mm
- Hex drive: 19mm – Use with Air Impact Wrench or 19mm socket /wrench
- Supplied with Vice Clamp for holding strut assemblies - Suitable for use with standard workstation accessories

€995.00



NEW

Optional Adaptors:

sp 38480100

Mercedes Bracket Set - A, C & E Class

€319.95

sp 38480200

Upper Jaw Set for High Compression Springs

€54.95

sp 38480400

Special Bracket Porsche Cayenne / VW Touareg

€139.95

sp 38480500

Special Bracket New Mercedes C Class

€239.95

sp 38480600

Special Bracket Nissan Qashqai

€129.95

sp 38480700

Double Depth Drop Vice

€159.95

SUSPENSION

NEW

sp 08390000

Heavy Duty Coil Spring Compressor

Unique Sykes-Pickavant design of vice-mounted Coil Spring Compressor

- Features double-ended hex drive (2 x 24mm hex) for ease of use
 - Can be operated from either end using ratchet or 24mm wrench
- Hex drives at both ends, incorporate shear-pins for safety
 - Features external thrust bearing for ease of service
 - Heat treated, Self-lubricating operating screw
- Safe Working Load = 15000N
- Supplied with two sets of universal jaws:
 - Medium Jaws – 110-150mm diameter
 - Large Jaws – 140-195mm diameter

OFFER €499.95
SAVE €133.20
 LIST PRICE €633.15



08390000 - Coil Spring Compressor fitted with Medium Jaws

EXCLUSIVE
sp SP Design



08390000 - Coil Spring Compressor fitted with Large & Small Jaws using Spacer Block



08390000 - Coil Spring Compressor featuring double-ended hex drive

Optional Jaws:

sp 08390100

Small Jaw
 80-115mm diameter



€69.95

sp 08390400

Extra Large Jaw
 180-240mm diameter



€99.95

NB – Optional Jaws are supplied as single jaws, which can be inter-changed for use on tapered springs

sp 08390500

Coil Spring Adaptors Kit

- Spacer Block for use with asymmetric / tapered springs
- Extensions (pair) for use with extra long strut assemblies

OFFER €189.95
SAVE €25.38
 LIST PRICE €215.33

sp 08390600

Spacer Block Only

€59.95

sp 08390700

Extensions Only (pair)

€159.95

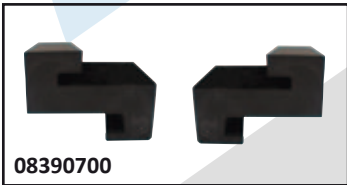

08390700



08390600

Special Application Jaws:

sp 08400700

BMW E39/E46, Megane2, Avensis



€229.95

sp 08400800

Merc C Class



€169.95

sp 08400900

Merc E Class



€169.95

sp 08391100

Plastic Jaw Covers - Small (pair)



€9.95

sp 08391200

Plastic Jaw Covers - Medium (pair)

€10.95

sp 08391300

Plastic Jaw Covers - Large (pair)

€11.95



ENGINE SERVICING



SP 01485000

21 Pc. Sump Plug Key Set

- Suitable for sump plug, engine, gear box, back axle applications
 - 8mm, 9mm, 10mm, 12mm, 13mm, 14mm, 17mm Hex
 - 7mm, 8mm, 10mm, 11mm, 12mm, 13mm, 14mm Square
 - 5/16", 3/8" Square
 - 10mm (XS10) Square female (BMW, Ford, Renault, Toyota Gearbox / Diff)
 - M16 Spline tamperproof (VAG Gearbox)
 - 10mm Triangular (Renault)
 - T45 Torx
- 3/8" sq drive c/w sliding T-Bar

OFFER €49.95
SAVE €17.48
LIST PRICE €67.43



SP 08529500

Camshaft and Crankshaft Seal Kit

- Remove & Install Camshaft Seals & Crankshaft Seals
 - Universal coverage for seals 27-58mm diameter
- Contents:**
- Seal Puller c/w short & long Extracting Hooks
 - Selection of Bushes, Sleeves and Mandrels for installing new seals

OFFER €119.95
SAVE €48.80
LIST PRICE €168.75



SP 03818000

Heavy Duty Oil Filter Remover Cars & LCV's

- Heavy Duty gear mechanism & construction
- Suitable for oil filters: 80 - 120mm
- 3/8" sq dr with 1/2 sq dr adaptor

OFFER €39.95
SAVE €23.50
LIST PRICE €63.45

SP 07742500

Ribbed Pulley Puller

- Adjustable 2 leg puller for removing Automotive Pulleys
- Puller grips the grooves on the pulley
- Suitable for pulley diameters: 130 - 155mm

OFFER €79.95
SAVE €34.80
LIST PRICE €114.75



SP 03875000

Oil Filter Wrench Belt Type c/w moulded handle

- Adjustable from 65mm - 105mm
- Twist mechanism to adjust belt
- Soft grip handle



OFFER €15.95
SAVE €4.23
LIST PRICE €20.18

SP 07744400

Stretch Belt Tool for Double Pulley applications

- Specially designed two-piece tool for installing and dismantling stretch belts on double pulleys where the two pulleys are of different diameters
- Allows the belt to be installed in one operation
- Ideal for Ford Focus applications

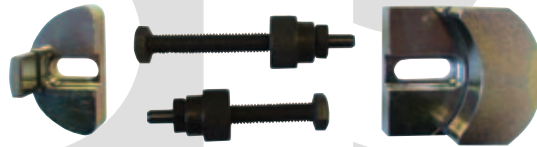

OFFER €119.95
SAVE €41.38
LIST PRICE €161.33

SP 01679500

Alternator Free Wheel Pulley Set - 18 piece updated set

- Special set of Spline & Torx Socket Bits for the removal of Bosch, Marelli & Valeo type alternator free-wheel drive pulleys
- Locks the alternator, allowing the central locking bolt of the pulley to be released
- BMW / Ford / Mercedes / Renault / VAG - with Bosch, Marelli & Valeo type alternators

OFFER €79.95
SAVE €27.98
LIST PRICE €107.93



ENGINE TIMING

sp 07752200

Ford Duratorq Diesel Engine Timing Kit

Applications

- Diesel Ford Duratorq
1.4TDCi, 2.0TDCi, 2.4Di (Belt & Chain models)
PSA 1.4, 1.6HDI

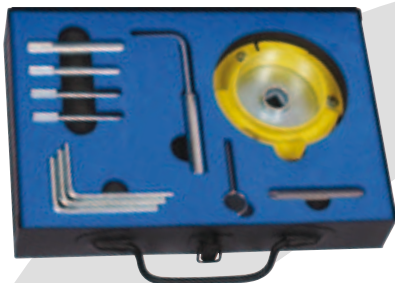

OFFER €134.95
SAVE €43.25
LIST PRICE €178.20

sp 07752300

Ford Zetec Timing Tool Kit

Applications

- 1.25 / 1.4 / 1.6 / 1.8 / 2.0 - 16v Petrol
Updated to include latest 1.6 TI-VCT Series
e.g. Focus / CMax 1.6



OFFER €19.95
SAVE €10.43
LIST PRICE €30.38

sp 07753200

GM Vauxhall & Opel Ecotec Engine Timing Kit

Applications

- Petrol GM 1.0, 1.2 - 12v
1.2, 1.4 - 16v



OFFER €94.43
SAVE €31.79
LIST PRICE €126.23

sp 07756100

VAG Group 1.2 - 6v & 12v 3 Cylinder Engine Timing Kit

Applications

- Petrol VAG Group 1.2-3



OFFER €79.95
SAVE €21.23
LIST PRICE €101.18

sp 07755200

Renault DCi Diesel Engine Timing Kit

Applications

- Renault - 1.5DCi, 1.9DCi, 2.2DCi
- Nissan - 1.5DCi
- Opel - 2.2, 2.5 TDi



OFFER €199.95
SAVE €90.30
LIST PRICE €290.25

sp 07755100

Renault 16v Petrol Engine Timing Kit

Applications

- Renault 1.4, 1.6, 1.8, 2.0 - 16v



OFFER €67.43
SAVE €23.69
LIST PRICE €91.13

sp 07756200

VAG 2.0TDi Diesel Engine Timing Kit

Applications

- VAG 2.0TDi PD Series

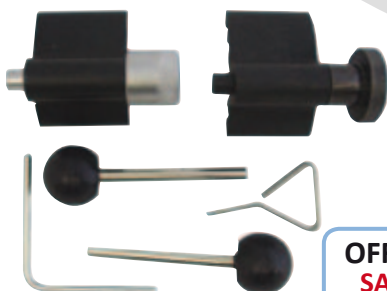

OFFER €53.95
SAVE €20.30
LIST PRICE €74.25

sp 07753600

PSA, Ford & Volvo Engine Timing Kit

Applications

- Peugeot, Citroen - 1.4, 1.6 HDi
- Volvo - S40 / V40 1.9TD ('01-'04)
- S40 / V50 1.6D ('04-'08)
- Ford - 1.4, 1.6 DCi



OFFER €53.93
SAVE €21.60
LIST PRICE €75.53

DIAGNOSTIC

Electronic service & repair work on today's modern vehicles can be complicated but with the new solution from Sykes-Pickavant SPe - this is safer and easier.

SPe is an advanced handheld **Automotive Electronic Service, Bodywork or Diagnostic Tool**, for use on all vehicles equipped with an EOBD socket, which have modern electronic service functionality built-in.

SPe - Automotive Electronic Service, Bodywork & Diagnostic Tool

- SPe guides the user through the electronic service functions
- SPe makes the decisions – the user only needs to select what they want to do
- SPe includes software for all the Electronic Service, Bodywork & Diagnostic functions on the vast majority of popular cars
- SPe scans all of the ECU's on the vehicle
- SPe creates a report of functions requiring service when the vehicle arrives
- SPe also creates a report to show that all work has been completed
- Fault code reading & clearing for all ECU's on the vehicle
- SPe includes relevant technical & maintenance data built in for guidance

SPe - NOW AVAILABLE WITH THREE SOFTWARE OPTIONS!

30653500 - SPe Electronic Workshop

An invaluable aid for the Diagnostic Technician that includes ALL of the below Service & Bodywork functions PLUS:

- Access to ALL of the Electronic modules on the vehicle
- Complete Vehicle ECU scans
- Reset Engine & Fuel System Parameters
- Injector & Component Coding

€2795.00
ANNUAL SUBSCRIPTION:
€675.00

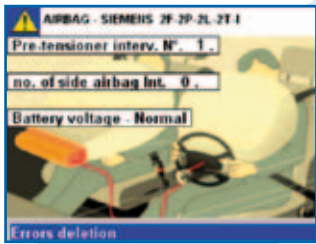

Airbag Fault



Alignment / Suspension Check

To read more about SPe, scan the QR Code below



30652500 - SPe Electronic Bodywork

An invaluable aid to assessing accident damage and estimating the cost of repair to vehicle electronic systems

SPe allows adjustment or programming following Bodywork Repair

Vehicle Acceptance Report - Automatic

- Actuator Test (Fans, mirrors, windows, lights, valves, pumps)
- Airbag & ECU Enabling & Coding
- Central Locking & Immobilizer & Anti-Theft Controls
- Comfort Controls
- Key & Remote Control Coding
- Aircan & Climate Control System Controls
- Body Computer Controls
- CAN Network Status
- Transmission & Gearbox Controls
- ABS / Traction / ESP Controls
- Steering & Suspension System
- Doors / Lights / Seats / Mirror / Parking Controls
- Display Check & Reset

Maintenance & Technical Data

Vehicle Delivery Report - Automatic

€2149.00
ANNUAL SUBSCRIPTION:
€337.50

30650000 - SPe Electronic Service

Work with ease on modern vehicles with electronically controlled service functions

SPe allows adjustment of all Service Functions

Vehicle Acceptance Report - Automatic

- Service Light & Service Module Reset
- Oil Degradation
- Engine Systems Check
- FAP / DPF Filter Regeneration
- Electronic Park Brake & Pad Change
- Brake & Clutch Bleeding
- Power & Electronic Steering Controls
- Suspension Controls
- ABS / ESP System
- Battery & Charging System
- Lighting Systems
- Aircan Systems
- Tyres & TPMS Systems

Maintenance & Technical Data

Vehicle Delivery Report - Automatic

€1995.00
ANNUAL SUBSCRIPTION:
€337.50

BOTH BODYWORK & SERVICE VERSIONS OF SPe CAN BE UPGRADED TO WORKSHOP LEVEL - ASK FOR DETAILS

WORKSHOP EQUIPMENT

€499.95

sp 30047500

Wireless Electronic Stethoscope - "ChassisEAR"

- The Wireless Electronic Stethoscope is designed for the detection of vehicle noises, e.g. rattles, squeaks and air ingress under load, during a road test and for the diagnosis of a wide variety of potential faults - E.G. Wheel bearings, CV joints, differentials, transmission, injectors, alternators, water pumps and AC compressors
- Can be used on cars, vans, trucks, buses etc as there are no cable length issues to overcome
- Consists of Receiver Unit, 4 x Transmitter Units (4 channels), 4 pick-up leads, pick-up fixing straps, headphones, batteries, instruction manual & storage case
- Pick-up clamps can be attached to many different parts of the vehicle in order to amplify the sounds made under load and in actual driving conditions

N.B. Due care and consideration should be taken of driving conditions and driving regulations when operating the ChassisEAR™ on the road.



NEW

INCLUDES FREE
VACUUM /
PRESSURE KIT
WORTH
€155.00!

sp 34300100

Automatic Brake Bleeder - 12v

- Compatible with ABS systems
- 12v powering with reverse polarity warning
- New pump with automatic power off valve
- Regulator from 0 to 3Bar
- 5l reservoir with visible level and min level indication
- Auto power OFF when min level reached
- 12V power cable with jack (L: 4m)
- Fluid cable for brake fluid with quick coupling system (L: 4m)
- Includes fluid collection bottle and European screw-on reservoir cap
- Stainless steel body

Includes
- Dual Vacuum & Pressure Pump
- 480ml Fluid Reservoir
- Selection of caps, tubing & tube connectors

€769.95



NEW

INCLUDES FREE
PLIERS SET
WORTH
€48.00!

sp 36600500

Fuel Extractor / Retriever

Retrieve fuel following a filling error (e.g. petrol instead of diesel, etc.), removal of tank sender unit, changing or checking the fuel gauge, rinsing the fuel tank during body work etc.

- Operates from workshop compressed air (no risk of sparks)
- Mobile 45-litre tank (on wheels)
- Cleanly draws up or pushes out fuel due to a venturi system
- Includes 2 anti-static ground cables, overflow line and 3 fuel probes
- Emptying via the tank filler neck or fuel lines
- Made of stainless steel



- 3 Pc. Set of Self Locking Pliers

Includes

- Heavy Duty Pliers
 - 9" Long Nose
 - 8" Engineer
 - 7" Side Cutters

€559.95



WORKSHOP TOOLS



SP 01800000

Screw Extractor Set

- For the removal of broken studs: 6mm - 12mm diameter
- Broken stud is drilled and an extractor is used to remove the remains of the stud
- **Set includes:**
 - 5 x Drill Bits
 - 10 x Drill Guides
 - 5 x Extractor Assemblies

OFFER €119.95
SAVE €48.80
 LIST PRICE €168.75

SP 66195000

Concentric Roller Stud Extractor Set

- 4 x sizes: 1/2 sq. dr. x M6, M8, M10, M12



OFFER €39.95
SAVE €16.08
 LIST PRICE €56.03

SP 04010100

Impact Driver & Bits Set

- For use with a medium weight hammer, to loosen stubborn screws and nuts
- Supplied in storage case with seven inter-changeable bits

OFFER €34.95
SAVE €14.66
 LIST PRICE €49.61

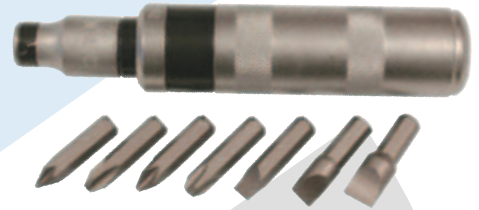

SP 67000600

Magnetic Pick-Up Tool

- Magnetic telescopic extension - 135 - 480mm extended length



OFFER €7.95
SAVE €2.18
 LIST PRICE €10.13



Thread Restorers

- For repairing damaged threads where a conventional die cannot be used
- Each restorer provides eight pitch sizes of thread form

SP 01560100

Thread Restorer

- Thread Form: SAE / UNF
- Pitch Sizes: 12, 13, 14, 16, 18, 20, 24, 28

OFFER €19.95
SAVE €6.04
 LIST PRICE €25.99

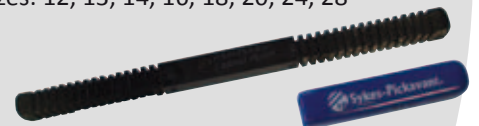

SP 01560200

Thread Restorer

- Thread Form: Metric
- Pitch Sizes: 0.75, 1.00, 1.25, 1.50, 1.75, 2.00, 2.50, 3.00

OFFER €19.95
SAVE €6.04
 LIST PRICE €25.99



OFFER €195.00
SAVE €54.75
 LIST PRICE €249.75



SP 66099000

5 Pc. Screw Extractor Set

- Spiral LH screw extractors (easy-outs)
- 3 - 19mm capacity

OFFER €10.95
SAVE €3.83
 LIST PRICE €14.78

SP 031600V2

Hydraulic Nut Splitter

- Removes seized nuts without damaging threads
- Includes Allen Key hex drive
- 20mm capacity
- Replacement cutter available



OFFER €69.95
SAVE €19.49
 LIST PRICE €89.44

SP 033600V2

Hydraulic Nut Splitter

- Removes seized nuts without damaging threads
- Includes Allen Key hex drive
- 37mm capacity
- Replacement cutter available

BODYSHOP

OFFER €339.95
SAVE €78.55
 LIST PRICE €418.50



SP 058500TH

"Thatcham Accredited" 13 Pc. Body Repair Kit

Body Repair Kit Contents:

- Thin Convex Curved Dolly
- Thin Toe Dolly
- Utility Dolly
- Pein & Crown Faced Beater
- Straight Pein & Flat Faced Beater Hammer
- Pick & Flat Face Beater Hammer
- Shrinking Flat Faced Beater Hammer
- Pry Spoon
- Bumping Tool Flat
- Adjustable Holder
- Body Blades - 1 x 6TPI, 1 x 9TPI, 1 x 12TPI



SP 04310000

Door Skin Crimping Tool

- Hand held tool for crimping and bending flanges when replacing door skins & panels
- Replaceable nylon pads prevent damage to doors when crimping

OFFER €99.95
SAVE €33.70
 LIST PRICE €133.65



OFFER €13.95
SAVE €6.23
 LIST PRICE €20.18



SP 04550000

Trim Tool Set

- Set of five plastic trim tools, ideal for roof linings, door trims, panel trims and moulding strips
- Manufactured from strong flexible plastic
- Includes angled, lever and panel pullers

OFFER €59.95
SAVE €20.38
 LIST PRICE €80.33

SP 08245000

4 Way Mini Puller - Ideal for Windscreen Wiper Arms

- Unique 4 way design allows for 4 different jaw widths to be selected
- Reversible and interchangeable legs
- Removable centrepiece for wider applications coverage
- Capacity from 19 – 36mm



SP 04600000

Trim Clip Remover and Plier

- For quick removal of clips, fasteners, door trim panels, fascia supports, trim panels
- Large nose allows trim panels to be unhooked with no risk of breaking or tearing
- Squeeze prevention pin



OFFER €29.95
SAVE €6.43
 LIST PRICE €36.38

CryoCobalt™ Drill

CryoCobalt™ Drills are specially designed for drilling very hard metals. Ideal for spot welds in High Strength Alloy steels & Ultra High Strength Boron steels. Added Cobalt increases micro-sharpness and operating temperatures. Cryophase process improves flexibility and extends bit operating life. CryoCobalt™ drills can be re-sharpened.

NEW

SP 04026500

CryoCobalt™ Drill - 6.5mm

€17.95



SP 04028000

CryoCobalt™ Drill - 8mm

€24.95



SP 05320000

Copper / Rawhide Mallet

- Double-ended mallet, ideal for bodyshop use - 1.1kg weight



OFFER €39.95
SAVE €7.30
 LIST PRICE €47.25

OFFER €34.95
SAVE €6.90
 LIST PRICE €41.85



SP 05310000

Rubber Faced Mallet

- Double-ended mallet, ideal for aluminium
- Replaceable rubber faces

SPOT WELD DRILL			LIST PRICE	OFFER PRICE	
04001100	Zip-Cut	5/16" HEX	€17.21	€11.95	
04020100	Stubby	8.0mm	€14.78	€10.95	
04021300	Stubby	6.5mm	€14.78	€10.95	
04021100	Jobber	8.0mm	€21.53	€14.95	
04022000	Jobber	6.5mm	€21.53	€14.95	



OTC3108

Pocketscan Plus – OBD11 / EOBD Scan Tool

The most advanced, powerful and compact code reader available!

- Suitable for OBD11 (1996-), EOBD (Petrol 2001-), (Diesel 2004-) and Hybrids
- Ideal for 'before & after' fault code checking
- Small size – only 0.27kg – ideal for toolbox storage



Menu Selection



'P' Code Displayed



€99.95

€139.95

OTC3109

Autoscanner – OBD11 / EOBD Scan Tool

The next generation of Scan Tool – professional grade scan tool features at a code reader price!

- Suitable for OBD11 (1996-), EOBD (Petrol 2001-), (Diesel 2004-) and Hybrids
- Includes graphing of live engine sensor data in real time
- Ideal for pin-pointing problems and quick diagnosis
- Lightweight hand held unit – only 0.36kg



Live Engine Data



Graphing Live Data

OTC3108 – Pocketscan Plus	OTC3109 - Autoscanner
Compatible with OBD11 & EOBD 1996 -	Compatible with OBD11 & EOBD 1996 -
Read, Display & Clear DTC's • P, B, C, U codes • 4,000 Generic Codes	Read, Display & Clear DTC's • P, B, C, U codes • 27,000 Generic & Specific Codes
Live Engine Data	Live Engine Data
Display & Reset MIL	Display & Reset MIL
Display Freeze Frame Data	Display Freeze Frame Data
Display I/M monitor status	Display I/M monitor status
Display VIN	Display VIN, CVN, Cal ID
	Communication Status
	EOBD Emissions State Check
	EOBD Drive Cycle Mode
	Graphing of Live Data
Single Language	Multi-Lingual (6 languages selection)

NEW

OTC SUSPENSION

**SP OTC6735****€199.95****Sprinter Van Front End Service Kit**

- Set of special tools for servicing suspension components on Sprinter Vans (2003-07)

Contents:

- Tied rod remover / Separator
- Ball Joint Remover
- Wheel Alignment Studs
- Ball Joint Removal Receiver & Installation Rings
- Use this kit with OTC 6736 C-Frame for installing new ball joints

**SP OTC6736****€154.95****Large C Frame**

- For use with OTC6735 Sprinter Front End Service Kit when installing new Ball Joints on Sprinter Vans

**SP OTC6530****€449.95****Ball Joint Super Set**

- Enables the user to remove and install ball joints without removing the control arm from the vehicle
- The OTC designed and produced C-frame tool can be used alone to remove and replace universal joints
- Comes complete with an application cross-reference and instructions in a blow-molded case
- Applications: Most cars and LCV's that have press-fit type ball joints

**SP OTC7249****Ball Joint Service Kit****€139.95**

- A universal set of tools for the Removal & Installation of press-fit parts:
- E.g. Ball Joints, Universal Joints and light truck brake anchor pins

Contents:

- Universal C - Frame
- 3 x receiver tubes (42 / 54 / 66mm I.D.)
- Installation and removing adaptors

**SP OTC7248****Universal C - Frame Press**

- For the Removal & Installation of a wide variety of Automotive Joints and Anchor Pins

**€107.93****SP OTC6980****Brake Drum & Rotor Puller**

- Safely handles large components such as brake drums, hubs, drive wheels, gears, flywheels, and pulleys
- One person can easily install the tool in position and use for tough pulling tasks, even where there is only limited access to insert the jaws
- Ideal where corrosion creates excessive resistance – special jaw design optimises load distribution
- 300mm Spread – 120mm Reach
- Provides 7-tons of force, yet weighs less than 5kg (10lbs)
- Can be used with air tools to reduce time and fatigue
- Nylon Ratcheting Safety Strap included

**€168.75****SP OTC7311A****Pitman Arm Puller**

- Adjustable Puller with replaceable forged jaws
- Two clamp bolts lock jaws on Pitman arm
- Universal applications
- Ideal for LCV's and light duty trucks

**€76.28***"Tool & Equipment Innovation Awards" – USA – Winner 2011*www.sykes-pickavant.com

9412

12 Pc. Combination Ratcheting Wrench Set

- 8, 9, 10, 11, 12, 13, 14, 15, 16, 17, 18, 19mm



€119.95



81915

3 Pc. Flex Flare Nut Wrench Set

- 9x11, 10x12, 13x14

€34.95

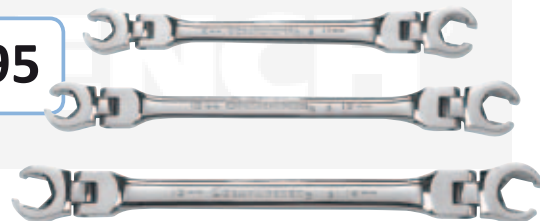

9520

10 Pc. Combination Stubby Ratcheting Wrench Set

- 10, 11, 12, 13, 14, 15, 16, 17, 18, 19mm

€89.95



85098

12 Pc. XL Combination Ratcheting Wrench Set

- 8, 9, 10, 11, 12, 13, 14, 15, 16, 17, 18, 19mm
- 25% longer than standard wrenches

€189.95



Ratcheting Box End needs as little as 5° to move fasteners, versus 30° for standard box end wrenches. All GearWrench Ratchet Wrenches feature Surface Drive® Technology

9620

12 Pc. Reversible Combination Ratcheting Wrench Set

- 8, 9, 10, 11, 12, 13, 14, 15, 16, 17, 18, 19mm



€134.95

9900

7 Pc. Flex Combination Ratcheting Wrench Set

- 10, 12, 13, 14, 15, 17, 19mm

€109.95



9901

12 Pc. Combination Flexible Ratcheting Wrench Set

- 8, 9, 10, 11, 12, 13, 14, 15, 16, 17, 18, 19mm

€189.95



8939

39 Pc. Ratcheting Screwdriver Set

- GearDriver handle
- 3 x Standard shafts
- 3 x Magnetic shafts
- 1 x Flexible shaft
- 30 Pc. Bit Set



€53.95

9230

3 Pc. Drive Adaptor Set

- 1/4 sq dr x 10mm
- 3/8 sq dr x 13mm
- 1/2 sq dr x 19mm



€24.95

8940

40 Pc. Ratcheting Screwdriver Set

- Standard Stubby, T-Handle & GearDriver Handles
- 2 x Standard shafts
- 2 x Magnetic shafts
- 2 x Flex shafts
- 30 Pc. Bit Set

€79.95

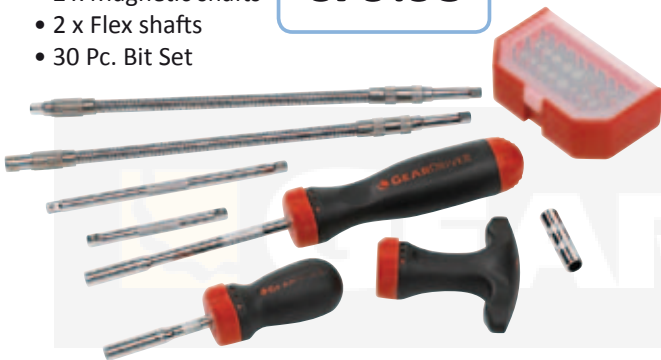

82781

Ratcheting Screwdriver c/w 6 Bits - "GearDriver"

- 1/8, 5/32, 3/16 Hex Bits
- #0, #1, #2 Phillips Bits



€22.95



3886

40 Pc. Ratcheting Tap & Die Tool Set - METRIC

- T-Wrench
- Tap & Die Adaptors
- 8 x Taper Taps / 8 x Plug Taps
- 16 x Dies

€149.95



3680GW

15 Pc. Serpentine Belt Tool Set

- 13, 14, 15, 16, 17, 18, 19mm 6pt Sockets
- 13, 14, 15mm Crowsfoot Wrenches
- 3/8, 1/2, 3/4 Adaptors

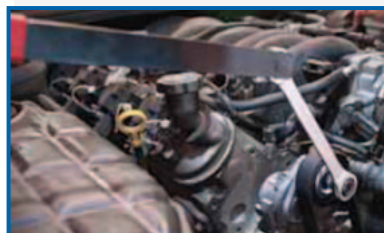
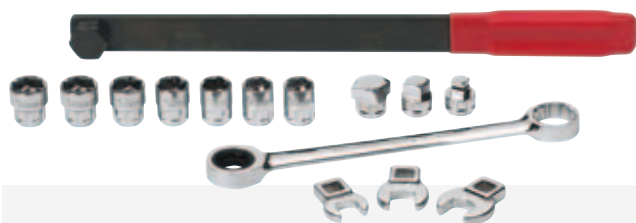

€94.95

81906

6 Pc. Flare Nut Non-Ratcheting Wrench Set

- 9x11, 10x12, 13x14, 15x17, 16x18, 19x21



€48.95

WORK WEAR



LCPNT205

Lee Cooper Cargo Work Trousers - Black

- 2 combat thigh pockets
- Pocket flaps with velcro
- Zip fly
- Belt loops
- 65% polyester / 35% cotton twill
- Available in waist sizes: 32", 34", 36", 38", 40", 42"
- Available in leg lengths: Short (30") Regular (32") Long (34")

€29.95



LCPNT213

Lee Cooper Heavy Duty 'Two Colour' Cargo Work Trousers - Black / Red Trim

- Multi-Tool Pockets & Combat Thigh Pocket
- Front & Rear Bellowed Pockets
- Mobile Phone Pocket
- Knee Pad Pockets (N.B. Kneepads must be ordered separately - See below)
- Belt loops with Lee Cooper logo at back
- Zip Fly
- Available in waist sizes: 32", 34", 36", 38", 40", 42"
- Available in leg lengths: Regular (32") Long (34")

€39.95

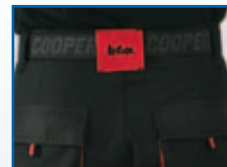

LCSCK603

Lee Cooper Heavy Duty Work Socks

- Rugged and hard wearing
- Black & Grey with red logo
- Warm & comfortable
- Pack of 5 pairs
- One size fits all



€13.95

LCBELT

Lee Cooper Belt

NEW

- Black Canvas Belt - 40mm wide
- Adjustable length
- Non-Scratch metal buckle with Lee Cooper logo
- One Size fits up to 46" waist
- Strong and flexible webbing for extra durability

€9.95



LCKP

Lee Cooper Kneepads - for Lee Cooper Heavy Duty Cargo Work Trousers (above)

- Ergonomic design
- Strong, comfortable, functional protection
- Extremely flexible when walking
- Material: EVA
- One size fits all



€9.95



NEW

LC008

Lee Cooper Safety Trainer - Black

- Penetration and Heat Resistant Mid-Soles
- Oil resistant and Anti-Static soles
- Steel toe Caps to ISO20345 standard
- Synthetic Uppers
- Available sizes: UK 7 - 12

€69.95

LCJKT415

Lee Cooper Lightweight Waterproof Jacket - Black

Total protection against wet conditions through waterproof fabric and taped seam technology

- Fully mesh-lined & waterproof
- Waterproof, breathable and windproof fabric for comfort
- Reflective detailing for visibility
- Adjustable velcro cuffs
- Bungee cord and toggle for adjusting hem & hood
- Zip fastening and outer side pockets
- Available sizes: - M, L, XL, XXL

NEW

€59.95



LCTS003

Lee Cooper Technical Polo Shirt - Black

A revolutionary polo shirt, manufactured from fabric which allows you to feel more comfortable through its breathable and wicking qualities

- Sportswear design, fit & styling
- Contrasting red placket and grey side panels with pockets
- 100% polyester pique fabric
- Available sizes: - M, L, XL, - XXL, XXXL

NEW

€24.95



Distributor Stamp:

Sykes-Pickavant Ltd, Unit 4 Cannel Road, Burntwood Business Park, Burntwood, Staffs, WS7 3FU. United Kingdom
Tel: +44 (0) 1543 679900 Fax: +44 (0) 1543 679901

e-mail: sales@sykes-pickavant.com www.sykes-pickavant.com

ALL PRICES QUOTED EXCLUDE VAT & ARE SUBJECT TO AVAILABILITY - E&OE - PRICES VALID UNTIL 30TH JUNE 2012 - REF: SPQ212EURO
COPYRIGHT 2012 - SYKES-PICKAVANT LTD. ALL RIGHTS RESERVED.